

Collections

Agenda

1. Introduction
2. Limitations of Object[] array
3. Differences between Arrays and Collections ?
4. 9(Nine) key interfaces of collection framework
 - i. Collection
 - ii. List
 - iii. Set
 - iv. SortedSet
 - v. NavigableSet
 - vi. Queue
 - vii. Map
 - viii. SortedMap
 - ix. NavigableMap
5. What is the difference between Collection and Collections ?
6. In collection framework the following are legacy characters
7. Collection interface
8. List interface
9. ArrayList
 - o Differences between ArrayList and Vector ?
 - o Getting synchronized version of ArrayList object

LinkedList

Vector

Stack

The 3 cursors of java

0. Enumeration
1. Iterator
2. ListIterator
 - o Compression of Enumeration , Iterator and ListIterator ?

Set interface

HashSet

LinkedHashSet

Diff b/w HashSet & LinkedHashSet

SortedSet

TreeSet

- o Null acceptance

Comparable interface

compareTo() method analysis

Comparator interface

Compression of Comparable and Comparator ?

Compression of Set implemented class objects

Map

Entry interface

HashMap

- Differences between HashMap and Hashtable ?
- How to get synchronized version of HashMap

LinkedHashMap

IdentityHashMap

WeakHashMap

SortedMap

TreeMap

Hashtable

Properties

1.5 v enhancements

- Queue interface
- PriorityQueue

1.6v Enhancements

- NavigableSet
- NavigableMap

Utility classes :

- Collections class
 - Sorting the elements of a List
 - Searching the elements of a List
 - Conclusions
- Arrays class
 - Sorting the elements of array
 - Searching the elements of array
 - Converting array to List

Introduction:

1. An array is an indexed collection of fixed no of homogeneous data elements. (or)
2. An array represents a group of elements of same data type.
3. The main advantage of array is we can represent huge no of elements by using single variable. So that readability of the code will be improved.

Limitations of Object[] array:

1. Arrays are fixed in size that is once we created an array there is no chance of increasing (or) decreasing the size based on our requirement hence to use arrays concept compulsory we should know the size in advance which may not possible always.
2. Arrays can hold only homogeneous data elements.

Example:

```
Student[] s=new Student[10000];  
s[0]=new Student();//valid
```

```
s[1]=new Customer();//invalid(compile time error)
```

Compile time error:

```
Test.java:7: cannot find symbol
```

```
Symbol: class Customer
```

```
Location: class Test
```

```
s[1]=new Customer();
```

3) But we can resolve this problem by using object type array(Object[]).

Example:

```
Object[] o=new Object[10000];
```

```
o[0]=new Student();
```

```
o[1]=new Customer();
```

4) Arrays concept is not implemented based on some data structure hence ready-made methods support we can't expect. For every requirement we have to write the code explicitly.

To overcome the above limitations we should go for collections concept.

1. Collections are growable in nature that is based on our requirement we can increase (or) decrease the size hence memory point of view collections concept is recommended to use.
2. Collections can hold both homogeneous and heterogeneous objects.
3. Every collection class is implemented based on some standard data structure hence for every requirement ready-made method support is available being a programmer we can use these methods directly without writing the functionality on our own.

Differences between Arrays and Collections ?

Arrays	Collections
1) Arrays are fixed in size.	1) Collections are growable in nature.
2) Memory point of view arrays are not recommended to use.	2) Memory point of view collections are highly recommended to use.
3) Performance point of view arrays are not recommended to use.	3) Performance point of view collections are not recommended to use.
4) Arrays can hold only homogeneous data type elements.	4) Collections can hold both homogeneous and heterogeneous elements.
5) There is no underlying data structure for arrays and hence there is no	5) Every collection class is implemented based on some standard data structure and hence

readymade method support.	readymade method support is available.
6) Arrays can hold both primitives and object types.	6) Collections can hold only objects but not primitives.

Collection:

If we want to represent a group of objects as single entity then we should go for collections.

Collection framework:

It defines several classes and interfaces to represent a group of objects as a single entity.

Java	C++
Collection	Containers
Collection framework	STL(Standard Template Library)

9(Nine) key interfaces of collection framework:

1. Collection
2. List
3. Set
4. SortedSet
5. NavigableSet
6. Queue
7. Map
8. SortedMap
9. NavigableMap

Collection:

1. If we want to represent a group of "individual objects" as a single entity then we should go for collection.
2. In general we can consider collection as root interface of entire collection framework.
3. Collection interface defines the most common methods which can be applicable for any collection object.
4. There is no concrete class which implements Collection interface directly.

List:

1. It is the child interface of Collection.
2. If we want to represent a group of individual objects as a single entity where "duplicates are allow and insertion order must be preserved" then we should go for List interface.

Diagram:

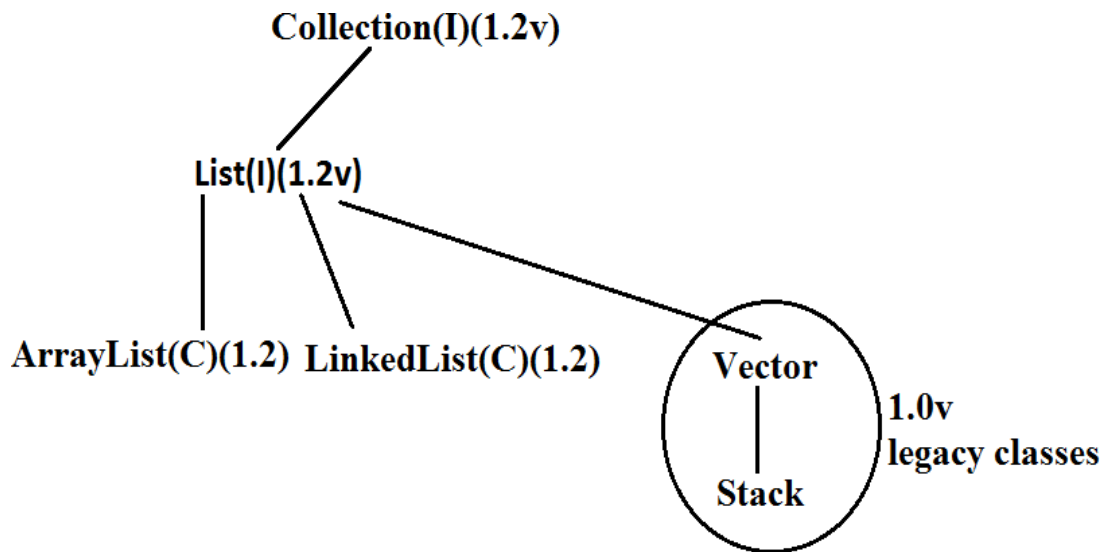

Vector and Stack classes are re-engineered in 1.2 versions to implement List interface.

Set:

1. It is the child interface of Collection.
2. If we want to represent a group of individual objects as single entity "where duplicates are not allow and insertion order is not preserved" then we should go for Set interface.

Diagram:

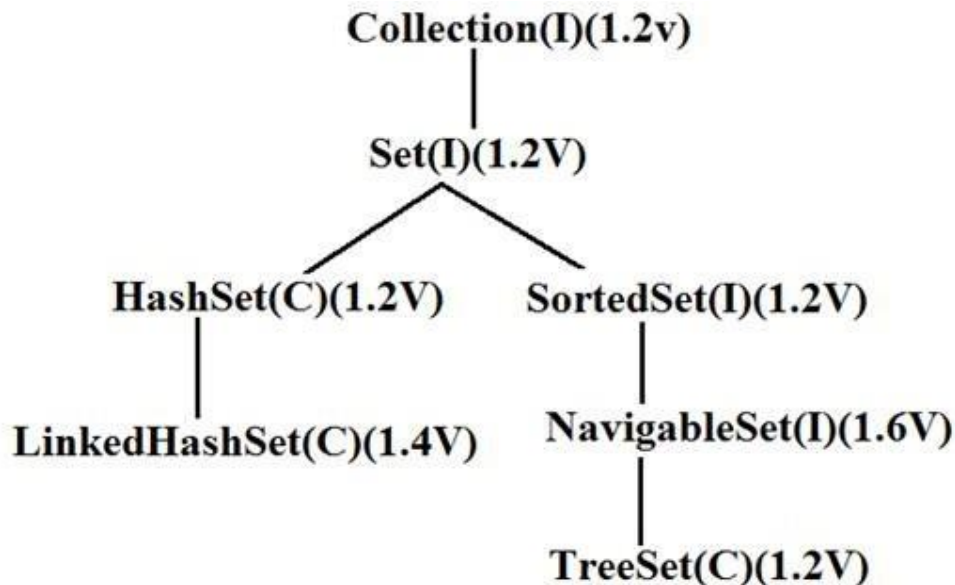

SortedSet:

1. It is the child interface of Set.
2. If we want to represent a group of individual objects as single entity "where duplicates are not allow but all objects will be insertion according to some sorting order then we should go for SortedSet.
(or)
3. If we want to represent a group of "unique objects" according to some sorting order then we should go for SortedSet.

NavigableSet:

1. It is the child interface of SortedSet.
2. It provides several methods for navigation purposes.

Queue:

1. It is the child interface of Collection.
2. If we want to represent a group of individual objects prior to processing then we should go for queue concept.

Diagram:

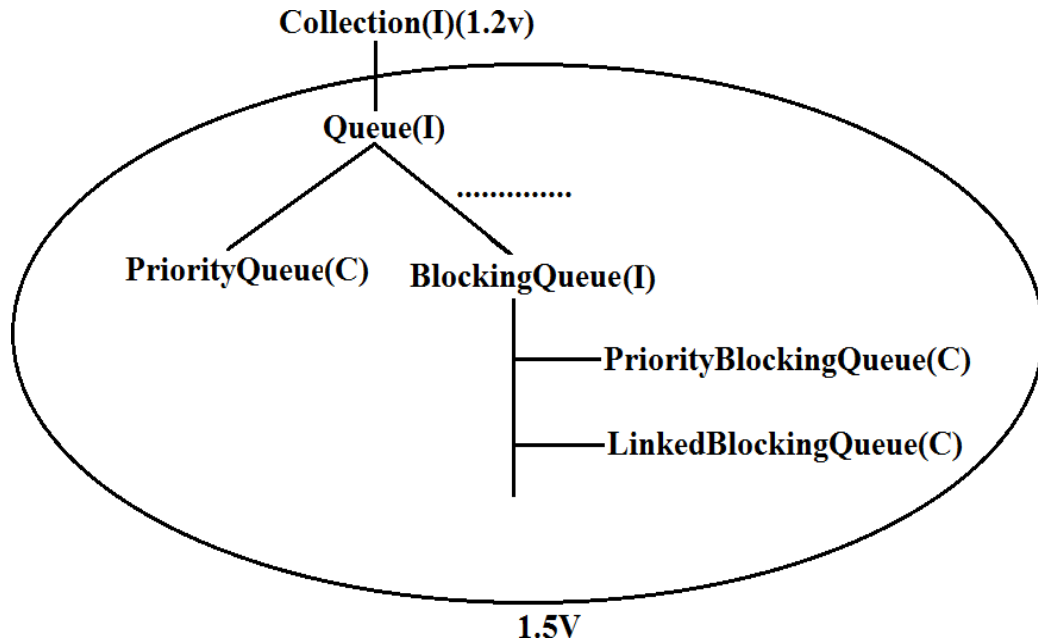

Note: All the above interfaces (Collection, List, Set, SortedSet, NavigableSet, and Queue) meant for representing a group of individual objects.
 If we want to represent a group of objects as key-value pairs then we should go for Map.

Map:

1. Map is not child interface of Collection.
2. If we want to represent a group of objects as key-value pairs then we should go for Map interface.
3. Duplicate keys are not allowed but values can be duplicated.

Diagram:

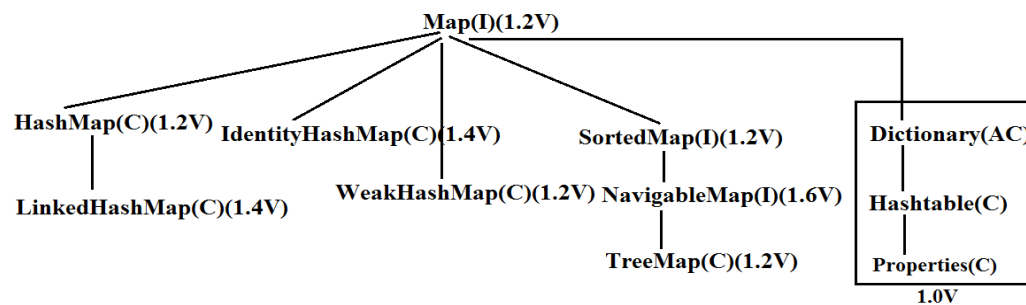

SortedMap:

1. It is the child interface of Map.
2. If we want to represent a group of objects as key value pairs "according to some sorting order of keys" then we should go for SortedMap.

NavigableMap:

1) It is the child interface of SortedMap and defines several methods for navigation purposes.

What is the difference between Collection and Collections ?

"Collection is an "interface" which can be used to represent a group of objects as a single entity. Whereas "Collections is an utility class" present in java.util package to define several utility methods for Collection objects.

Collection----- interface
Collections ----- class

In collection framework the following are legacy characters.

1. Enumeration(I)
2. Dictionary(AC)
3. Vector(C)
4. Stack(C)
5. Hashtable(C)
6. Properties(C)

Diagram:

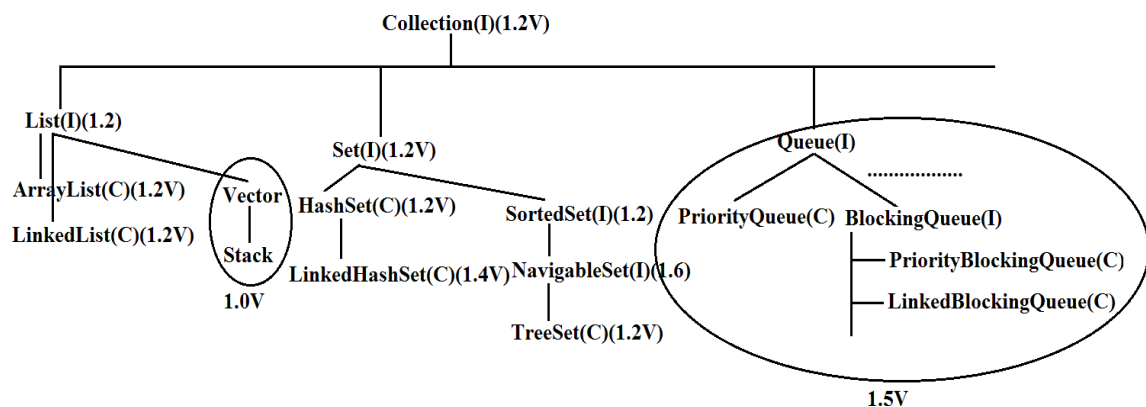
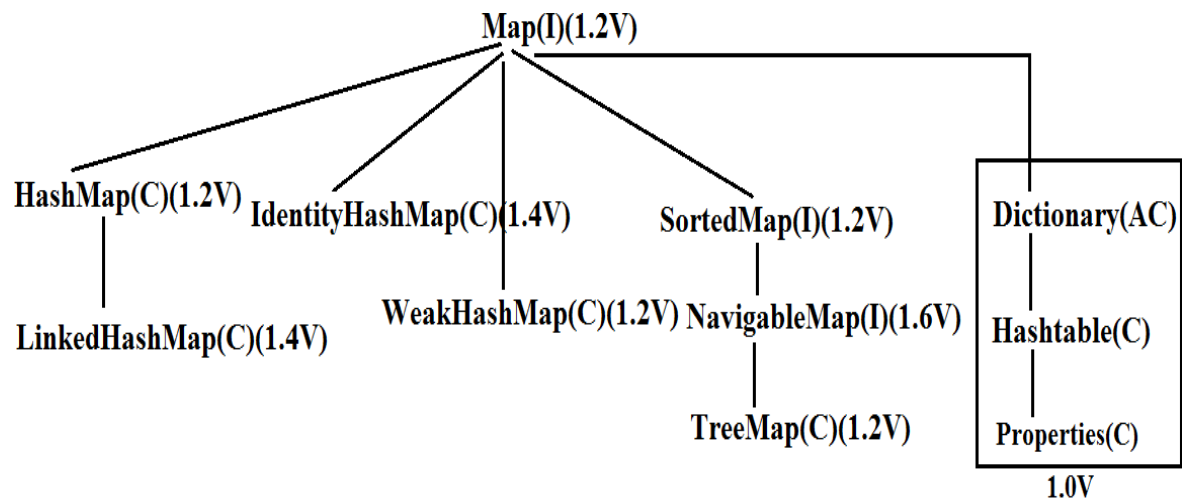

Diagram:



Collection interface:

- If we want to represent a group of individual objects as a single entity then we should go for Collection interface. This interface defines the most common general methods which can be applicable for any Collection object.
- The following is the list of methods present in Collection interface.
 1. boolean add(Object o);
 2. boolean addAll(Collection c);
 3. boolean remove(Object o);
 4. boolean removeAll(Object o);
 5. boolean retainAll(Collection c);
To remove all objects except those present in c.
 6. Void clear();
 7. boolean contains(Object o);
 8. boolean containsAll(Collection c);
 9. boolean isEmpty();
 10. Int size();
 11. Object[] toArray();
 12. Iterator iterator();

There is no concrete class which implements Collection interface directly.

List interface:

- It is the child interface of Collection.
- If we want to represent a group of individual objects as a single entity where duplicates are allow and insertion order is preserved. Then we should go for List.
- We can differentiate duplicate objects and we can maintain insertion order by means of index hence "index play very important role in List".

List interface defines the following specific methods.

1. `boolean add(int index, Object o);`
2. `boolean addAll(int index, Collection c);`
3. `Object get(int index);`
4. `Object remove(int index);`
5. `Object set(int index, Object new);` //to replace
6. `int indexOf(Object o);`
Returns index of first occurrence of "o".
7. `int lastIndexOf(Object o);`
8. `ListIterator listIterator();`

ArrayList:

1. The underlying data structure is resizable array (or) growable array.
2. Duplicate objects are allowed.
3. Insertion order preserved.
4. Heterogeneous objects are allowed.(except TreeSet , TreeMap everywhere heterogeneous objects are allowed)
5. Null insertion is possible.

Constructors:

1) `ArrayList a=new ArrayList();`

Creates an empty ArrayList object with default initial capacity "10" if ArrayList reaches its max capacity then a new ArrayList object will be created with

$$\underline{\text{New capacity}=(\text{current capacity}*3/2)+1}$$

2) `ArrayList a=new ArrayList(int initialcapacity);`

Creates an empty ArrayList object with the specified initial capacity.

3) `ArrayList a=new ArrayList(collection c);`

Creates an equivalent ArrayList object for the given Collection that is this constructor meant for inter conversation between collection objects. That is to dance between collection objects.

Demo program for ArrayList:

```
import java.util.*;
class ArrayListDemo
{
    public static void main(String[] args)
    {
        ArrayList a=new ArrayList();
    }
}
```

```

        a.add("A");
        a.add(10);
        a.add("A");
        a.add(null);
        System.out.println(a);//[A, 10, A, null]
        a.remove(2);
        System.out.println(a);//[A, 10, null]
        a.add(2,"m");
        a.add("n");
        System.out.println(a);//[A, 10, m, null, n]
    }
}

```

- Usually we can use collection to hold and transfer objects from one tier to another tier. To provide support for this requirement every Collection class already implements Serializable and Cloneable interfaces.
- ArrayList and Vector classes implements RandomAccess interface so that any random element we can access with the same speed. Hence ArrayList is the best choice of "retrival operation".
- RandomAccess interface present in util package and doesn't contain any methods. It is a marker interface.

Example :

```

ArrayList a1=new ArrayList();
LinkedList a2=new LinkedList();

System.out.println(a1 instanceof Serializable ); //true
System.out.println(a2 instanceof Clonable); //true

System.out.println(a1 instanceof RandomAccess); //true
System.out.println(a2 instanceof RandomAccess); //false

```

Differences between ArrayList and Vector ?

ArrayList	Vector
1) No method is synchronized	1) Every method is synchronized
2) At a time multiple Threads are allow to operate on ArrayList object and hence ArrayList object is not Thread safe.	2) At a time only one Thread is allow to operate on Vector object and hence Vector object is Thread safe.
3) Relatively performance is high because Threads are not required to wait.	3) Relatively performance is low because Threads are required to wait.

4) It is non legacy and introduced in 1.2v

4) It is legacy and introduced in 1.0v

Getting synchronized version of ArrayList object:

- Collections class defines the following method to return synchronized version of List.

Public static List synchronizedList(list l);

- Example:

```
ArrayList a=new arrayList();
```

```
List l1=collections.synchronizedList(a);
```

**synchronized
version**

**nonsynchronized
version**

- Similarly we can get synchronized version of Set and Map objects by using the following methods.

1) public static Set synchronizedSet(Set s);

2) public static Map synchronizedMap(Map m);

- ArrayList is the best choice if our frequent operation is retrieval.
- ArrayList is the worst choice if our frequent operation is insertion (or) deletion in the middle because it requires several internal shift operations.

Diagram:

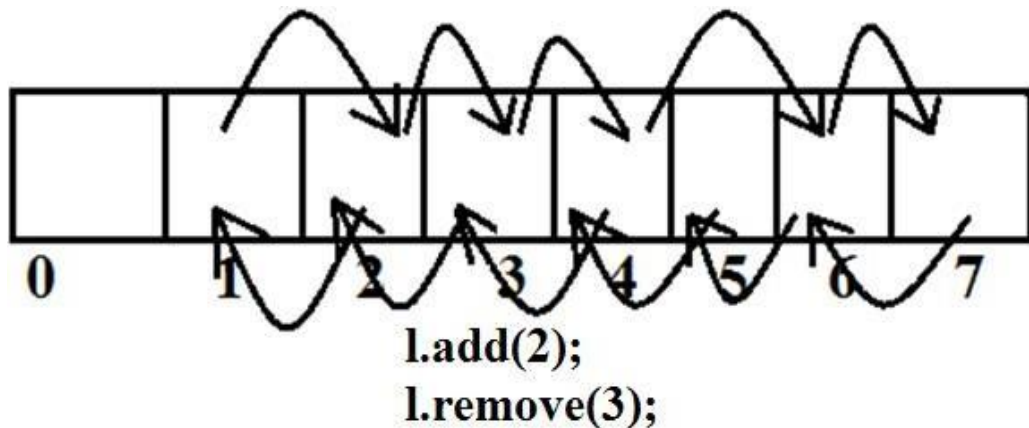

[LinkedList:](#)

1. The underlying data structure is double LinkedList
2. If our frequent operation is insertion (or) deletion in the middle then LinkedList is the best choice.
3. If our frequent operation is retrieval operation then LinkedList is worst choice.
4. Duplicate objects are allowed.
5. Insertion order is preserved.
6. Heterogeneous objects are allowed.
7. Null insertion is possible.
8. Implements Serializable and Cloneable interfaces but not RandomAccess.

Diagram:

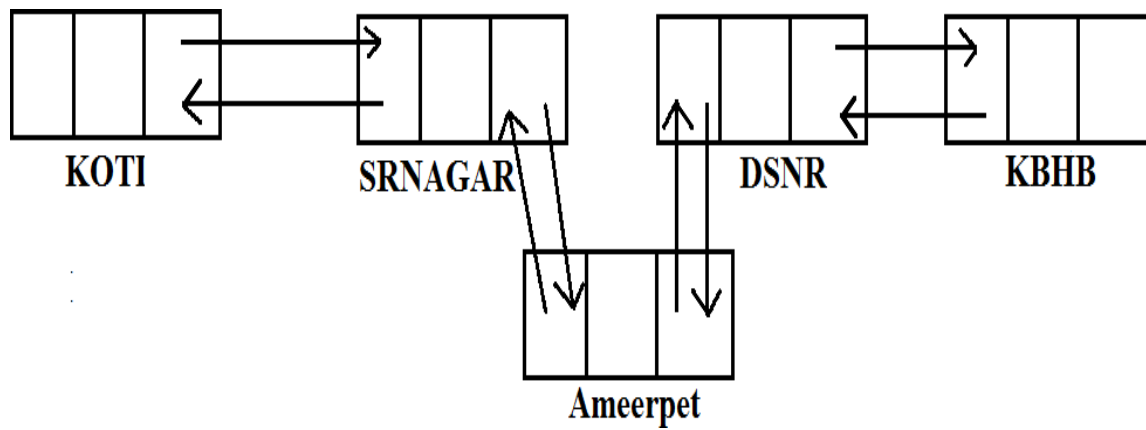

Usually we can use LinkedList to implement Stacks and Queues.

To provide support for this requirement LinkedList class defines the following 6 specific methods.

1. void addFirst(Object o);
2. void addLast(Object o);
3. Object getFirst();
4. Object getLast();
5. Object removeFirst();
6. Object removeLast();

We can apply these methods only on LinkedList object.

Constructors:

1. LinkedList l=new LinkedList();
Creates an empty LinkedList object.

2. LinkedList l=new LinkedList(Collection c);

To create an equivalent LinkedList object for the given collection.

Example:

```
import java.util.*;
class LinkedListDemo
{
    public static void main(String[] args)
    {
        LinkedList l=new LinkedList();
        l.add("ashok");
        l.add(30);
        l.add(null);
        l.add("ashok");
        System.out.println(l);//[ashok, 30, null, ashok]
        l.set(0,"software");
        System.out.println(l);//[software, 30, null,
ashok]
        l.set(0,"venky");
        System.out.println(l);//[venky, 30, null, ashok]
        l.removeLast();
        System.out.println(l);//[venky, 30, null]
        l.addFirst("vvv");
        System.out.println(l);//[vvv, venky, 30, null]
    }
}
```

Vector:

1. The underlying data structure is resizable array (or) growable array.
2. Duplicate objects are allowed.
3. Insertion order is preserved.
4. Heterogeneous objects are allowed.
5. Null insertion is possible.
6. Implements Serializable, Cloneable and RandomAccess interfaces.

Every method present in Vector is synchronized and hence Vector is Thread safe.

Vector specific methods:

To add objects:

1. add(Object o);---- Collection
2. add(int index,Object o);-----List
3. addElement(Object o);----- Vector

To remove elements:

-
1. remove(Object o);----- Collection
 2. remove(int index); -----List
 3. removeElement(Object o); --- Vector
 4. removeElementAt(int index);----- Vector
 5. removeAllElements(); -----Vector
 6. clear(); ----- Collection

To get objects:

1. Object get(int index);----- List
2. Object elementAt(int index); ---- Vector
3. Object firstElement(); -----Vector
4. Object lastElement();----- Vector

Other methods:

1. Int size();//How many objects are added
2. Int capacity();//Total capacity
3. Enumeration elements();

Constructors:

1. Vector v=new Vector();
 - Creates an empty Vector object with default initial capacity 10.
 - Once Vector reaches its maximum capacity then a new Vector object will be created with double capacity. That is "newcapacity=currentcapacity*2".
2. Vector v=new Vector(int initialcapacity);
3. Vector v=new Vector(int initialcapacity, int incrementalcapacity);
4. Vector v=new Vector(Collection c);

Example:

```
import java.util.*;
class VectorDemo
{
    public static void main(String[] args)
    {
        Vector v=new Vector();
        System.out.println(v.capacity()); //10
        for(int i=1;i<=10;i++)
        {
            v.addElement(i);
        }
        System.out.println(v.capacity()); //10
        v.addElement("A");
        System.out.println(v.capacity()); //20
        System.out.println(v); // [1, 2, 3, 4, 5, 6, 7, 8, 9, 10,
A]
    }
}
```

}

Stack:

1. It is the child class of Vector.
2. Whenever last in first out(LIFO) order required then we should go for Stack.

Constructor:

It contains only one constructor.

```
Stack s= new Stack();
```

Methods:

1. Object push(Object o);
To insert an object into the stack.
2. Object pop();
To remove and return top of the stack.
3. Object peek();
To return top of the stack without removal.
4. boolean empty();
Returns true if Stack is empty.
5. Int search(Object o);
Returns offset if the element is available otherwise returns "-1"

Example:

```
import java.util.*;
class StackDemo
{
    public static void main(String[] args)
    {
        Stack s=new Stack();
        s.push("A");
        s.push("B");
        s.push("C");
        System.out.println(s);//[A, B, C]
        System.out.println(s.pop());//C
        System.out.println(s);//[A, B]
        System.out.println(s.peek());//B
        System.out.println(s.search("A"));//2
        System.out.println(s.search("Z"));//-1
        System.out.println(s.empty());//false
    }
}
```

Iterator:

1. We can use Iterator to get objects one by one from any collection object.
2. We can apply Iterator concept for any collection object and it is a universal cursor.
3. While iterating the objects by Iterator we can perform both read and remove

operations.

We can get Iterator object by using iterator() method of Collection interface.

```
public Iterator iterator();  
Iterator itr=c.iterator();
```

Iterator interface defines the following 3 methods.

1. public boolean hasNext();
2. public Object next();
3. public void remove();

Example:

```
import java.util.*;  
class IteratorDemo  
{  
    public static void main(String[] args)  
    {  
        ArrayList a=new ArrayList();  
        for(int i=0;i<=10;i++)  
        {  
            a.add(i);  
        }  
        System.out.println(a);//[0, 1, 2, 3, 4, 5, 6, 7,  
8, 9, 10]  
        Iterator itr=a.iterator();  
        while(itr.hasNext())  
        {  
            Integer i=(Integer)itr.next();  
            if(i%2==0)  
                System.out.println(i);//0, 2, 4, 6,  
8, 10  
            else  
                itr.remove();  
        }  
    }  
}
```

```
    }  
    System.out.println(a); //[0, 2, 4, 6, 8, 10]  
  }  
}
```

Limitations of Iterator:

1. Both enumeration and Iterator are single direction cursors only. That is we can always move only forward direction and we can't move to the backward direction.
2. While iterating by Iterator we can perform only read and remove operations and we can't perform replacement and addition of new objects.
3. To overcome these limitations sun people introduced listIterator concept.

Set interface:

1. It is the child interface of Collection.
2. If we want to represent a group of individual objects as a single entity where duplicates are not allow and insertion order is not preserved then we should go for Set interface.

Diagram:

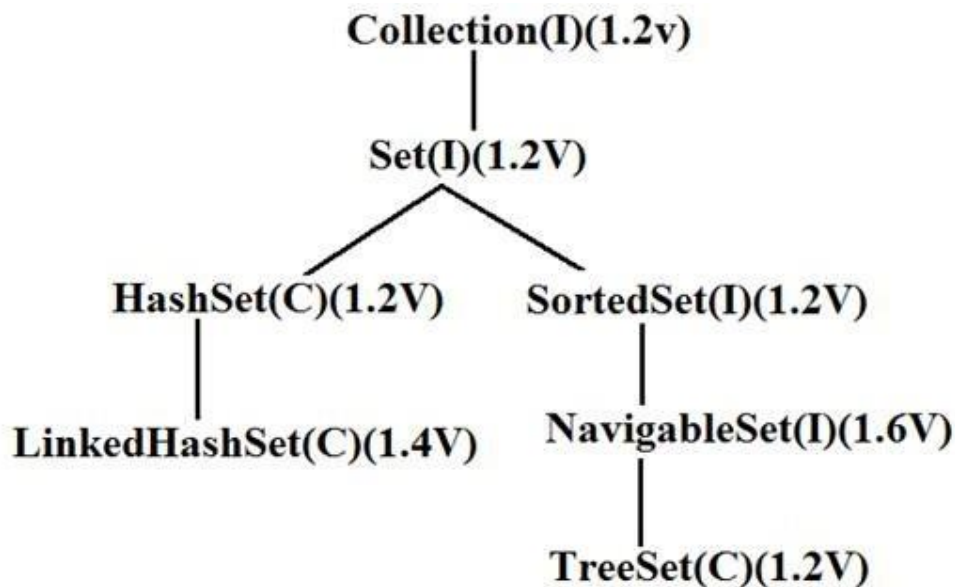

Set interface does not contain any new method we have to use only Collection interface methods.

HashSet:

1. The underlying data structure is Hashtable.
2. Insertion order is not preserved and it is based on hash code of the objects.
3. Duplicate objects are not allowed.
4. If we are trying to insert duplicate objects we won't get compile time error and runtime error add() method simply returns false.
5. Heterogeneous objects are allowed.
6. Null insertion is possible.(only once)
7. Implements Serializable and Cloneable interfaces but not RandomAccess.
8. HashSet is best suitable, if our frequent operation is "Search".

Constructors:

1. `HashSet h=new HashSet();`
Creates an empty HashSet object with default initial capacity 16 and default fill ratio 0.75(fill ratio is also known as load factor).
2. `HashSet h=new HashSet(int initialcapacity);`
Creates an empty HashSet object with the specified initial capacity and default fill ratio 0.75.
3. `HashSet h=new HashSet(int initialcapacity,float fillratio);`
4. `HashSet h=new HashSet(Collection c);`

Note : After filling how much ratio new HashSet object will be created , The ratio is called "FillRatio" or "LoadFactor".

Example:

```
import java.util.*;
class HashSetDemo
{
    public static void main(String[] args)
    {
        HashSet h=new HashSet();
        h.add("B");
        h.add("C");
        h.add("D");
        h.add("Z");
        h.add(null);
        h.add(10);
        System.out.println(h.add("Z")); //false
        System.out.println(h); // [null, D, B, C, 10, Z]
    }
}
```

LinkedHashSet:

1. It is the child class of HashSet.
2. LinkedHashSet is exactly same as HashSet except the following differences.

HashSet	LinkedHashSet
1) The underlying data structure is Hashtable.	1) The underlying data structure is a combination of LinkedList and Hashtable.
2) Insertion order is not preserved.	2) Insertion order is preserved.
3) Introduced in 1.2 v.	3) Introduced in 1.4v.

In the above program if we are replacing HashSet with LinkedHashSet the output is [B, C, D, Z, null, 10]. That is insertion order is preserved.

Example:

```
import java.util.*;
class LinkedHashSetDemo
{
    public static void main(String[] args)
    {
        LinkedHashSet h=new LinkedHashSet();
        h.add("B");
        h.add("C");
        h.add("D");
        h.add("Z");
        h.add(null);
        h.add(10);
        System.out.println(h.add("Z")); //false
        System.out.println(h); // [B, C, D, Z, null, 10]
    }
}
```

Note: LinkedHashSet and LinkedHashMap commonly used for implementing "cache applications" where insertion order must be preserved and duplicates are not allowed.

SortedSet:

1. It is child interface of Set.
2. If we want to represent a group of "unique objects" where duplicates are not allowed and all objects must be inserting according to some sorting order then we should go for SortedSet interface.
3. That sorting order can be either default natural sorting (or) customized sorting order.

SortedSet interface define the following 6 specific methods.

1. Object first();
2. Object last();
3. SortedSet headSet(Object obj);
Returns the SortedSet whose elements are <obj.
4. SortedSet tailSet(Object obj);
It returns the SortedSet whose elements are >=obj.
5. SortedSet subset(Object o1, Object o2);
Returns the SortedSet whose elements are >=o1 but <o2.
6. Comparator comparator();
 - Returns the Comparator object that describes underlying sorting technique.
 - If we are following default natural sorting order then this method returns null.

Diagram:

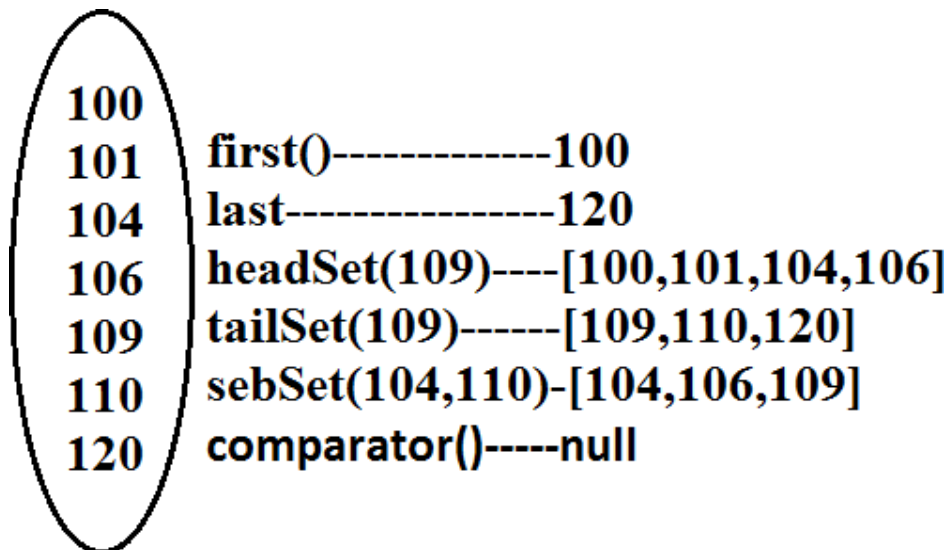

TreeSet:

1. The underlying data structure is balanced tree.
2. Duplicate objects are not allowed.
3. Insertion order is not preserved and it is based on some sorting order of objects.
4. Heterogeneous objects are not allowed if we are trying to insert heterogeneous objects then we will get ClassCastException.
5. Null insertion is possible(only once).

Constructors:

1. `TreeSet t=new TreeSet();`
Creates an empty `TreeSet` object where all elements will be inserted according to default natural sorting order.
2. `TreeSet t=new TreeSet(Comparator c);`
Creates an empty `TreeSet` object where all objects will be inserted according to customized sorting order specified by `Comparator` object.
3. `TreeSet t=new TreeSet(SortedSet s);`
4. `TreeSet t=new TreeSet(Collection c);`

Example 1:

```
import java.util.*;
class TreeSetDemo
{
    public static void main(String[] args)
    {
        TreeSet t=new TreeSet();
        t.add("A");
        t.add("a");
        t.add("B");
        t.add("Z");
        t.add("L");
        //t.add(new Integer(10)); //ClassCastException
        //t.add(null); //NullPointerException
        System.out.println(t); // [A, B, L, Z, a]
    }
}
```

Comparable interface:

Comparable interface present in java.lang package and contains only one method compareTo() method.

```
public int compareTo(Object obj);
```

Example:

```
obj1.compareTo(obj2);
```

Diagram:

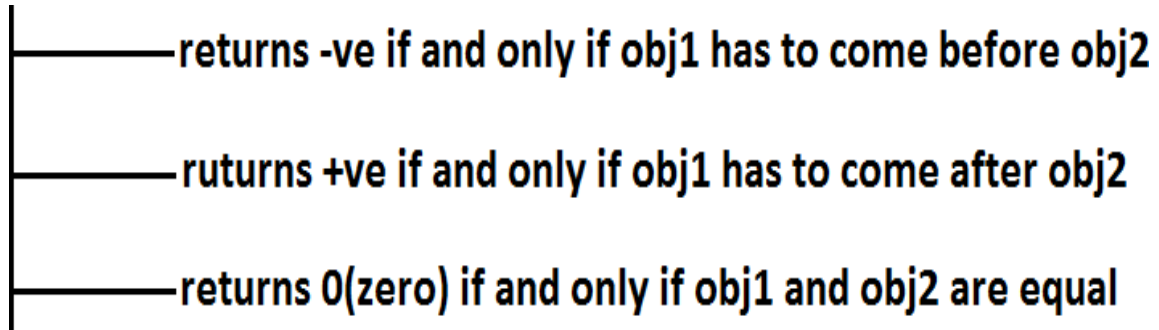

Example 3:

```
class Test
{
    public static void main(String[] args)
    {
        System.out.println("A".compareTo("Z")); //-25
    }
}
```

```

        System.out.println("Z".compareTo("K")); //15
        System.out.println("A".compareTo("A")); //0
        //System.out.println("A".compareTo(new
Integer(10)));
        //Test.java:8: compareTo(java.lang.String)
in java.lang.String cannot
        be applied to (java.lang.Integer)

        //System.out.println("A".compareTo(null)); //NullPointerException
}
}

```

If we are depending on default natural sorting order then internally JVM will use compareTo() method to arrange objects in sorting order.

Example 4:

```

import java.util.*;
class Test
{
    public static void main(String[] args)
    {
        TreeSet t=new TreeSet();
        t.add(10);
        t.add(0);
        t.add(15);
        t.add(10);
        System.out.println(t); // [0, 10, 15]
    }
}

```

compareTo() method analysis:

```

TreeSet t=new TreeSet();
t.add(10); → [10]
t.add(0); → -ve → 0.compareTo(10); [0,10]
t.add(15); → +ve → 15.compareTo(0); [0,15,10]
           → +ve → 15.compareTo(10); [0,10,15]
t.add(10); → +ve → 10.compareTo(0); 10
           ↓
           [0,10,15]
           → 0(zero) → 10.compareTo(10); [0,10,15]

```

- If we are not satisfying with default natural sorting order (or) if default natural sorting order is not available then we can define our own customized sorting by Comparator object.
- Comparable meant for default natural sorting order.
- Comparator meant for customized sorting order.

Comparator interface:

Comparator interface present in java.util package this interface defines the following 2 methods.

1) *public int compare(Object obj1, Object Obj2);*

Diagram:

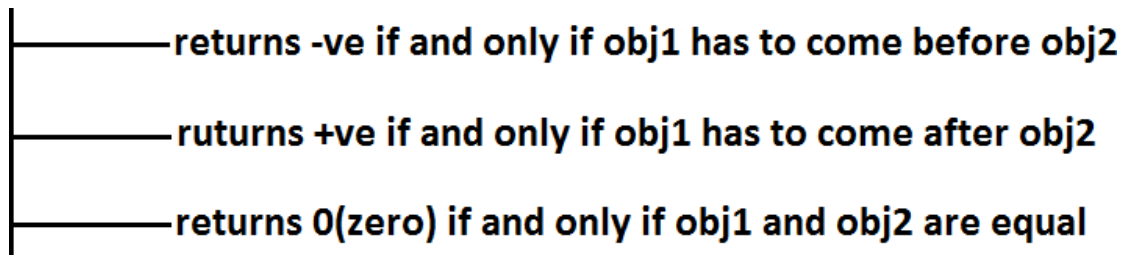

2) *public boolean equals(Object obj);*

- Whenever we are implementing Comparator interface we have to provide implementation only for `compare()` method.
- Implementing `equals()` method is optional because it is already available from Object class through inheritance.

Requirement: Write a program to insert integer objects into the TreeSet where the sorting order is descending order.

Program:

```
import java.util.*;
class Test
{
    public static void main(String[] args)
    {
        TreeSet t=new TreeSet(new MyComparator()); //---
->(1)      t.add(10);
           t.add(0);
           t.add(15);
           t.add(5);
           t.add(20);
    }
}
```

```

        System.out.println(t);//[20, 15, 10, 5, 0]
    }
}
class MyComparator implements Comparator
{
    public int compare(Object obj1,Object obj2)
    {
        Integer i1=(Integer)obj1;
        Integer i2=(Integer)obj2;
        if(i1<i2)
            return +1;
        else if(i1 > i2)
            return -100;
        else return 0;
    }
}

```

- At line "1" if we are not passing Comparator object then JVM will always calls compareTo() method which is meant for default natural sorting order(ascending order)hence in this case the output is [0, 5, 10, 15, 20].
- At line "1" if we are passing Comparator object then JVM calls compare() method of MyComparator class which is meant for customized sorting order(descending order) hence in this case the output is [20, 15, 10, 5, 0].

Diagram:

```

TreeSet t=new TreeSet(new MyComparator());
t.add(10); [10]
t.add(0);  $\xrightarrow{+ve}$  compare(0,10) [10,0]
t.add(15);  $\xrightarrow{-ve}$  compare(15,10)[15,10,0]
t.add(5);  $\xrightarrow{+ve}$  compare(5,15) [15,5,10,0]
 $\xrightarrow{+ve}$  compare(5,10) [15,10,5,0]
 $\xrightarrow{-ve}$  compare(5,0) [15,10,5,0]
t.add(20);  $\xrightarrow{\quad}$  compare(20,15) [20,15,10,5,0]

```

Various alternative implementations of compare() method:

```

public int compare(Object obj1,Object obj2)
{
    Integer i1=(Integer)obj1;
    Integer i2=(Integer)obj2;

```

```

        //return i1.compareTo(i2);//[0, 5, 10, 15, 20]
        //return -i1.compareTo(i2);//[20, 15, 10, 5, 0]
        //return i2.compareTo(i1);//[20, 15, 10, 5, 0]
        //return -i2.compareTo(i1);//[0, 5, 10, 15, 20]
        //return -1;//[20, 5, 15, 0, 10]//reverse of
insertion order
        //return +1;//[10, 0, 15, 5, 20]//insertion order
        //return 0;//[10]and all the remaining elements
treated as duplicate.
    }

```

Requirement: Write a program to insert String objects into the TreeSet where the sorting order is reverse of alphabetical order.

Program:

```

import java.util.*;
class TreeSetDemo
{
    public static void main(String[] args)
    {
        TreeSet t=new TreeSet(new MyComparator());
        t.add("Roja");
        t.add("ShobaRani");
        t.add("RajaKumari");
        t.add("GangaBhavani");
        t.add("Ramulamma");
        System.out.println(t);//[ShobaRani, Roja,
Ramulamma, RajaKumari, GangaBhavani]
    }
}
class MyComparator implements Comparator
{
    public int compare(Object obj1,Object obj2)
    {
        String s1=obj1.toString();
        String s2=(String)obj2;
        //return s2.compareTo(s1);
        return -s1.compareTo(s2);
    }
}

```

Requirement: Write a program to insert StringBuffer objects into the TreeSet where the sorting order is alphabetical order.

Program:

```

import java.util.*;
class TreeSetDemo
{
    public static void main(String[] args)
    {
        TreeSet t=new TreeSet(new MyComparator());
        t.add(new StringBuffer("A"));
    }
}

```

```

        t.add(new StringBuffer("Z"));
        t.add(new StringBuffer("K"));
        t.add(new StringBuffer("L"));
        System.out.println(t); // [A, K, L, Z]
    }
}
class MyComparator implements Comparator
{
    public int compare(Object obj1, Object obj2)
    {
        String s1=obj1.toString();
        String s2=obj2.toString();
        return s1.compareTo(s2);
    }
}

```

Note: Whenever we are defining our own customized sorting by Comparator then the objects need not be Comparable.

Example: StringBuffer

Requirement: Write a program to insert String and StringBuffer objects into the TreeSet where the sorting order is increasing length order. If 2 objects having the same length then consider they alphabetical order.

Program:

```

import java.util.*;
class TreeSetDemo
{
    public static void main(String[] args)
    {
        TreeSet t=new TreeSet(new MyComparator());
        t.add("A");
        t.add(new StringBuffer("ABC"));
        t.add(new StringBuffer("AA"));
        t.add("xx");
        t.add("ABCD");
        t.add("A");
        System.out.println(t); // [A, AA, xx, ABC, ABCD]
    }
}
class MyComparator implements Comparator
{
    public int compare(Object obj1, Object obj2)
    {
        String s1=obj1.toString();
        String s2=obj2.toString();
        int l1=s1.length();
        int l2=s2.length();
        if(l1 < l2)
            return -1;
        else if(l1 > l2)

```

```
        return 1;
    else
        return s1.compareTo(s2);
    }
}
```

Note: If we are depending on default natural sorting order then the objects should be "homogeneous and comparable" otherwise we will get ClassCastException. If we are defining our own sorting by Comparator then objects "need not be homogeneous and comparable".

Comparable vs Comparator:

- For predefined Comparable classes default natural sorting order is already available if we are not satisfied with default natural sorting order then we can define our own customized sorting order by Comparator.
- For predefined non Comparable classes [like StringBuffer] default natural sorting order is not available we can define our own sorting order by using Comparator object.
- For our own classes [like Customer, Student, and Employee] we can define default natural sorting order by using Comparable interface. The person who is using our class, if he is not satisfied with default natural sorting order then he can define his own sorting order by using Comparator object.

Example:

```
import java.util.*;
class Employee implements Comparable
{
    String name;
    int eid;
    Employee(String name,int eid)
    {
        this.name=name;
        this.eid=eid;
    }
    public String toString()
    {
        return name+"----"+eid;
    }
    public int compareTo(Object o)
    {
        int eid1=this.eid;
        int eid2=((Employee)o).eid;
        if(eid1 < eid2)
        {
            return -1;
        }
    }
}
```

```

    }
    else if(eid1 > eid2)
    {
        return 1;
    }
    else return 0;
}
}
class CompComp
{
    public static void main(String[] args)
    {
        Employee e1=new Employee("nag",100);
        Employee e2=new Employee("balaiah",200);
        Employee e3=new Employee("chiru",50);
        Employee e4=new Employee("venki",150);
        Employee e5=new Employee("nag",100);
        TreeSet t1=new TreeSet();
        t1.add(e1);
        t1.add(e2);
        t1.add(e3);
        t1.add(e4);
        t1.add(e5);
        System.out.println(t1);//[chiru----50, nag----
100, venki----150, balaiah --- 200]
        TreeSet t2=new TreeSet(new MyComparator());
        t2.add(e1);
        t2.add(e2);
        t2.add(e3);
        t2.add(e4);
        t2.add(e5);
        System.out.println(t2);//[balaiah----200, chiru--
--50, nag----100, venki --- 150]
    }
}
class MyComparator implements Comparator
{
    public int compare(Object obj1,Object obj2)
    {
        Employee e1=(Employee)obj1;
        Employee e2=(Employee)obj2;
        String s1=e1.name;
        String s2=e2.name;
        return s1.compareTo(s2);
    }
}

```

Compression of Comparable and Comparator ?

Comparable	Comparator
1) Comparable meant for default natural sorting order.	1) Comparator meant for customized sorting order.
2) Present in java.lang package.	2) Present in java.util package.
3) Contains only one method. compareTo() method.	3) Contains 2 methods. Compare() method. Equals() method.
4) String class and all wrapper Classes implements Comparable interface.	4) The only implemented classes of Comparator are Collator and RuleBasedCollator. (used in GUI)

Map:

Diagram:

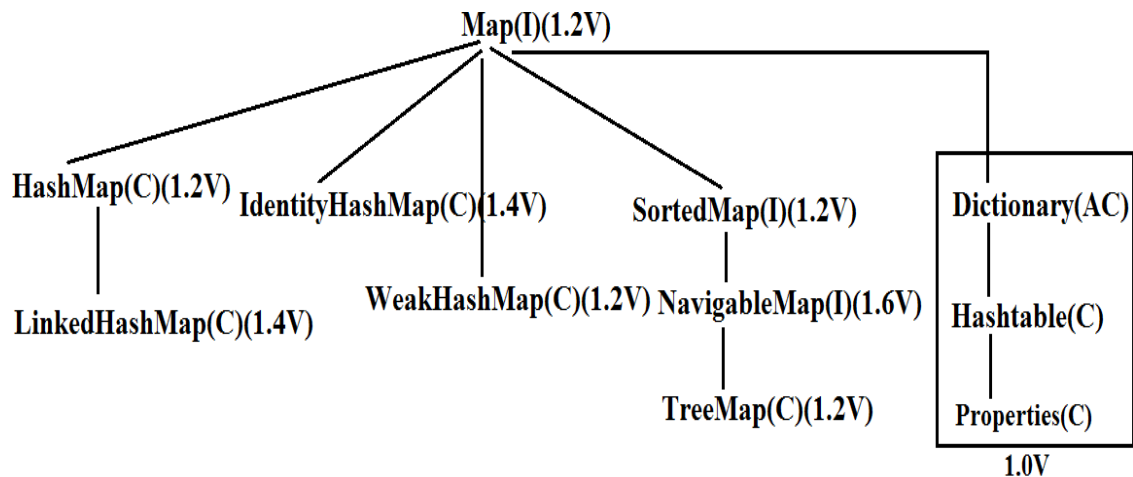

1. If we want to represent a group of objects as "key-value" pair then we should go for Map interface.
2. Both key and value are objects only.
3. Duplicate keys are not allowed but values can be duplicated
4. Each key-value pair is called "one entry".

Diagram:

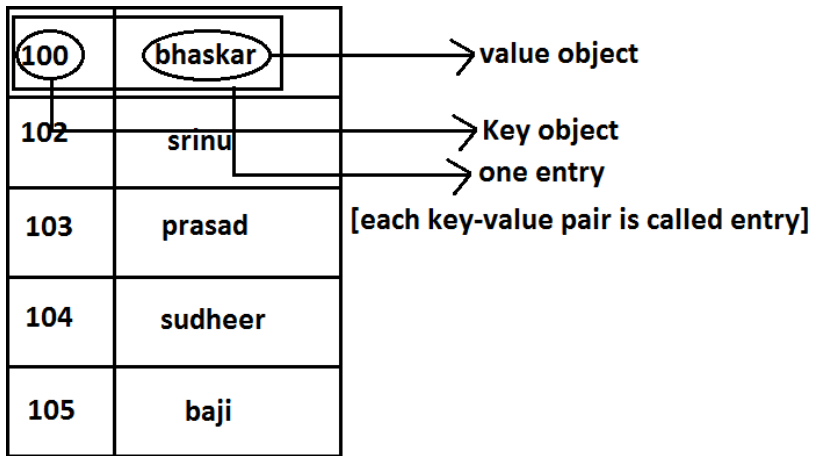

- Map interface is not child interface of Collection and hence we can't apply Collection interface methods here.
- Map interface defines the following specific methods.

1. Object put(Object key, Object value);

To add an entry to the Map, if key is already available then the old value replaced with new value and old value will be returned.

Example:

```
2. import java.util.*;
3. class Map
4. {
5.     public static void main(String[] args)
6.     {
7.         HashMap m=new HashMap();
8.         m.put("100","vijay");
9.         System.out.println(m); //{100=vijay}
10.        m.put("100","ashok");
11.        System.out.println(m); //{100=ashok}
12.    }
13. }
```

14. void putAll(Map m);

15. Object get(Object key);

16. Object remove(Object key);

It removes the entry associated with specified key and returns the corresponding value.

17. boolean containsKey(Object key);

18. boolean containsValue(Object value);

19. boolean isEmpty();

20. int size();

21. void clear();

22. Set keySet();

The set of keys we are getting.

23. Collection values();

The set of values we are getting.

24. Set entrySet();

The set of entryset we are getting.

Entry interface:

Each key-value pair is called one entry. Hence Map is considered as a group of entry Objects, without existing Map object there is no chance of existing entry object hence interface entry is define inside Map interface(inner interface).

Example:

```
interface Map
```

```

{
    .....;
    .....;
    .....;
    interface Entry
    {
        Object getKey();
        Object getValue();           on Entry we can
apply these 3 methods.
        Object setValue(Object new);
    }
}

```

HashMap:

1. The underlying data structure is Hashtable.
2. Duplicate keys are not allowed but values can be duplicated.
3. Insertion order is not preserved and it is based on hash code of the keys.
4. Heterogeneous objects are allowed for both key and value.
5. Null is allowed for keys(only once) and for values(any number of times).
6. It is best suitable for Search operations.

Differences between HashMap and Hashtable ?

HashMap	Hashtable
1) No method is synchronized.	1) Every method is synchronized.
2) Multiple Threads can operate simultaneously on HashMap object and hence it is not Thread safe.	2) Multiple Threads can't operate simultaneously on Hashtable object and hence Hashtable object is Thread safe.
3) Relatively performance is high.	3) Relatively performance is low.
4) Null is allowed for both key and value.	4) Null is not allowed for both key and value otherwise we will get NullPointerException.
5) It is non legacy and introduced in 1.2v.	5) It is legacy and introduced in 1.0v.

How to get synchronized version of HashMap:

By default HashMap object is not synchronized. But we can get synchronized version by using the following method of Collections class.

```
public static Map synchronizedMap(Map m1)
```

Constructors:

1. `HashMap m=new HashMap();`
Creates an empty HashMap object with default initial capacity 16 and default fill ratio "0.75".
2. `HashMap m=new HashMap(int initialcapacity);`
3. `HashMap m =new HashMap(int initialcapacity, float fillratio);`
4. `HashMap m=new HashMap(Map m);`

Example:

```
import java.util.*;
class HashMapDemo
{
    public static void main(String[] args)
    {
        HashMap m=new HashMap();
        m.put("chiranjeevi",700);
        m.put("balaiah",800);
        m.put("venkatesh",200);
        m.put("nagarjuna",500);

        System.out.println(m);//{nagarjuna=500,venkatesh=200,bal
aiah=800,chiranjeevi=700}

        System.out.println(m.put("chiranjeevi",100));//700
        Set s=m.keySet();

        System.out.println(s);//[nagarjuna,venkatesh,balaiah,chi
ranjeevi]
        Collection c=m.values();
        System.out.println(c);//[500, 200, 800, 100]
        Set s1=m.entrySet();

        System.out.println(s1);//[nagarjuna=500,venkatesh=200,ba
laih=800,chiranjeevi=100]
        Iterator itr=s1.iterator();
        while(itr.hasNext())
        {
            Map.Entry m1=(Map.Entry)itr.next();

            System.out.println(m1.getKey()+" ..... "+m1.getValue());
                //nagarjuna ..... 500
                //venkatesh.....200 //
                //balaiah..... 800
                //chiranjeevi ..... 100
            if(m1.getKey().equals("nagarjuna"))
            {
                m1.setValue(1000);
            }
        }
    }
}
```

```

    }
    System.out.println(m) ;

//{nagarjuna=1000,venkatesh=200,balaiah=800,chiranjeevi=100}
    }
}

```

LinkedHashMap:

It is exactly same as HashMap except the following differences :

HashMap	LinkedHashMap
1) The underlying data structure is Hashtable.	1) The underlying data structure is a combination of Hashtable+ LinkedList.
2) Insertion order is not preserved.	2) Insertion order is preserved.
3) introduced in 1.2.v.	3) Introduced in 1.4v.

Note: in the above program if we are replacing HashMap with LinkedHashMap then the output is {chiranjeevi=100, balaiah.....800, venkatesh.....200, nagarjuna 1000} that is insertion order is preserved.

Note: in general we can use LinkedHashSet and LinkedHashMap for implementing cache applications.

IdentityHashMap:

It is exactly same as HashMap except the following differences:

1. In the case of HashMap JVM will always use ".equals()" method to identify duplicate keys, which is meant for content comparison.
2. But in the case of IdentityHashMap JVM will use == (double equal operator) to identify duplicate keys, which is meant for reference comparison.

Example:

```

import java.util.*;
class HashMapDemo
{
    public static void main(String[] args)
    {
        HashMap m=new HashMap();
        Integer i1=new Integer(10);

```

```

        Integer i2=new Integer(10);
        m.put(i1,"pavan");
        m.put(i2,"kalyan");
        System.out.println(m);
    }
}

```

- In the above program i1 and i2 are duplicate keys because i1.equals(i2) returns true.
- In the above program if we replace HashMap with IdentityHashMap then i1 and i2 are not duplicate keys because i1==i2 is false hence in this case the output is {10=pavan, 10=kalyan}.

```

System.out.println(m.get(10)); //null
10==i1 ----- false
10==i2 ----- false

```

SortedMap:

- It is the child interface of Map.
- If we want to represent a group of key-value pairs according to some sorting order of keys then we should go for SortedMap.
- Sorting is possible only based on the keys but not based on values.
- SortedMap interface defines the following 6 specific methods.
 1. Object firsyKey();
 2. Object lastKey();
 3. SortedMap headMap(Object key);
 4. SortedMap tailMap(Object key);
 5. SortedMap subMap(Object key1,Object key2);

Comparator comparator();

Hashtable:

1. The underlying data structure is Hashtable.
2. Insertion order is not preserved and it is based on hash code of the keys.
3. Heterogeneous objects are allowed for both keys and values.
4. Null key (or) null value is not allowed otherwise we will get NullPointerException.
5. Duplicate keys are allowed but values can be duplicated.
6. Every method present inside Hashtable is synchronized and hence Hashtable objet is Thread-safe.

1. Constructors: Hashtable h=new Hashtable();
Creates an empty Hashtable object with default initialcapacity 11 and default fill ratio 0.75.
2. Hashtable h=new Hashtable(int initialcapacity);
3. Hashtable h=new Hashtable(int initialcapacity,float fillratio);
4. Hashtable h=new Hashtable (Map m);

Example:

```
import java.util.*;
```

```

class HashtableDemo
{
    public static void main(String[] args)
    {
        Hashtable h=new Hashtable();
        h.put(new Temp(5),"A");

        h.put(new Temp(2),"B");
        h.put(new Temp(6),"C");
        h.put(new Temp(15),"D");
        h.put(new Temp(23),"E");
        h.put(new Temp(16),"F");
        System.out.println(h); //{6=C, 16=F, 5=A, 15=D,
2=B, 23=E}
    }
}
class Temp
{
    int i;
    Temp(int i)
    {
        this.i=i;
    }
    public int hashCode()
    {
        return i;
    }
    public String toString()
    {
        return i+"";
    }
}

```

Queue interface

Diagram:

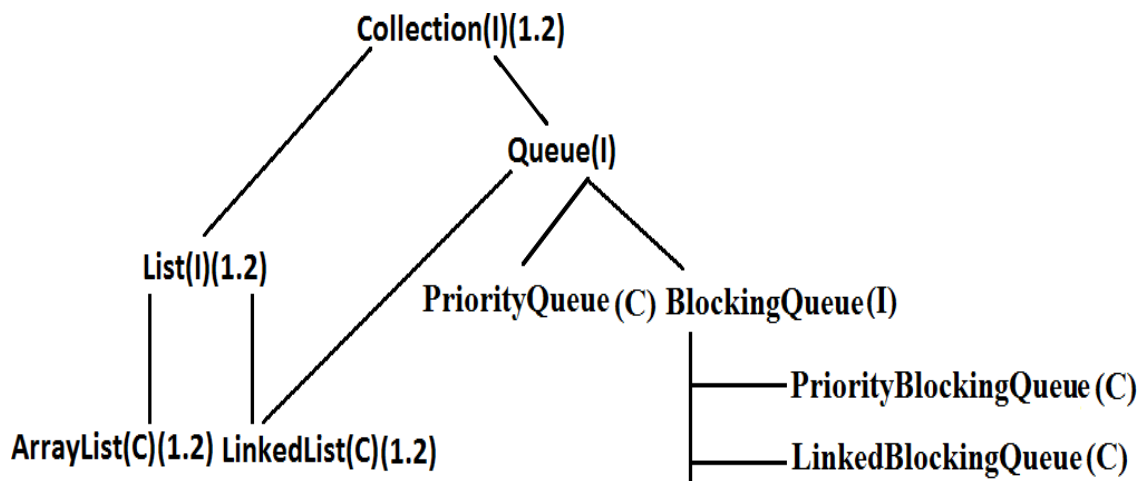

1. Queue is child interface of Collections.
2. If we want to represent a group of individual objects prior (happening before something else) to processing then we should go for Queue interface.
3. Usually Queue follows first in first out(FIFO) order but based on our requirement we can implement our own order also.
4. From 1.5v onwards LinkedList also implements Queue interface.
5. LinkedList based implementation of Queue always follows first in first out order.

Assume we have to send sms for one lakh mobile numbers , before sending messages we have to store all mobile numbers into Queue so that for the first inserted number first message will be triggered(FIFO).

Queue interface methods:

1. `boolean offer(Object o);`
To add an object to the Queue.
2. `Object poll();`
To remove and return head element of the Queue, if Queue is empty then we will get null.
3. `Object remove();`
To remove and return head element of the Queue. If Queue is empty then this method raises Runtime Exception saying NoSuchElementException.

4. Object peek();

To return head element of the Queue without removal, if Queue is empty this method returns null.

5. Object element();

It returns head element of the Queue and if Queue is empty then it will raise Runtime Exception saying NoSuchElementException.

PriorityQueue:

1. PriorityQueue is a data structure to represent a group of individual objects prior to processing according to some priority.
2. The priority order can be either default natural sorting order (or) customized sorting order specified by Comparator object.
3. If we are depending on default natural sorting order then the objects must be homogeneous and Comparable otherwise we will get ClassCastException.
4. If we are defining our own customized sorting order by Comparator then the objects need not be homogeneous and Comparable.
5. Duplicate objects are not allowed.
6. Insertion order is not preserved but all objects will be inserted according to some priority.
7. Null is not allowed even as the 1st element for empty PriorityQueue. Otherwise we will get the "NullPointerException".

Constructors:

1. PriorityQueue q=new PriorityQueue();
Creates an empty PriorityQueue with default initial capacity 11 and default natural sorting order.
2. PriorityQueue q=new PriorityQueue(int initialcapacity,Comparator c);
3. PriorityQueue q=new PriorityQueue(int initialcapacity);
4. PriorityQueue q=new PriorityQueue(Collection c);
5. PriorityQueue q=new PriorityQueue(SortedSet s);

Example 1:

```
import java.util.*;
class PriorityQueueDemo
{
    public static void main(String[] args)
    {
        PriorityQueue q=new PriorityQueue();
        //System.out.println(q.peek()); //null

        //System.out.println(q.element()); //NoSuchElementException
on
        for(int i=0;i<=10;i++)
        {
            q.offer(i);
        }
    }
}
```

```

        System.out.println(q);//[0, 1, 2, 3, 4, 5, 6, 7,
8, 9, 10]
        System.out.println(q.poll());//0
        System.out.println(q);//[1, 3, 2, 7, 4, 5, 6, 10,
8, 9]
    }
}

```

Note: Some platforms may not provide proper supports for PriorityQueue [windowsXP].

Example 2:

```

import java.util.*;
class PriorityQueueDemo
{
    public static void main(String[] args)
    {
        PriorityQueue q=new PriorityQueue(15,new
MyComparator());
        q.offer("A");
        q.offer("Z");
        q.offer("L");
        q.offer("B");
        System.out.println(q);//[Z, B, L, A]
    }
}
class MyComparator implements Comparator
{
    public int compare(Object obj1,Object obj2)
    {
        String s1=(String)obj1;
        String s2=obj2.toString();
        return s2.compareTo(s1);
    }
}

```

1.6 v Enhancements :

NavigableSet:

1. It is the child interface of SortedSet.
2. It provides several methods for navigation purposes.

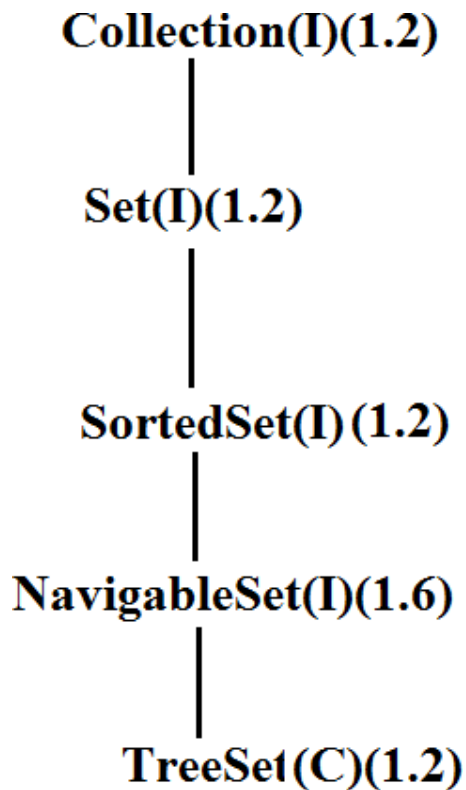

NavigableSet interface defines the following methods.

1. `ceiling(e)`;
It returns the lowest element which is $\geq e$.
2. `higher(e)`;
It returns the lowest element which is $> e$.
3. `floor(e)`;
It returns highest element which is $\leq e$.
4. `lower(e)`;
It returns height element which is $< e$.
5. `pollFirst ()`;
Remove and return 1st element.
6. `pollLast ()`;
Remove and return last element.
7. `descendingSet ()`;
Returns SortedSet in reverse order.

1000
2000
3000
4000
5000

Collections class:

Collections class defines several utility methods for collection objects.

Sorting the elements of a List:

Collections class defines the following methods to perform sorting the elements of a List.

```
public static void sort(List l);
```

- To sort the elements of List according to default natural sorting order in this case the elements should be homogeneous and comparable otherwise we will get `ClassCastException`.
- The List should not contain null otherwise we will get `NullPointerException`